

GEARBOX DRIVEN POWERED ROTATION

SM-AIR

OPERATION AND MAINTENANCE MANUAL

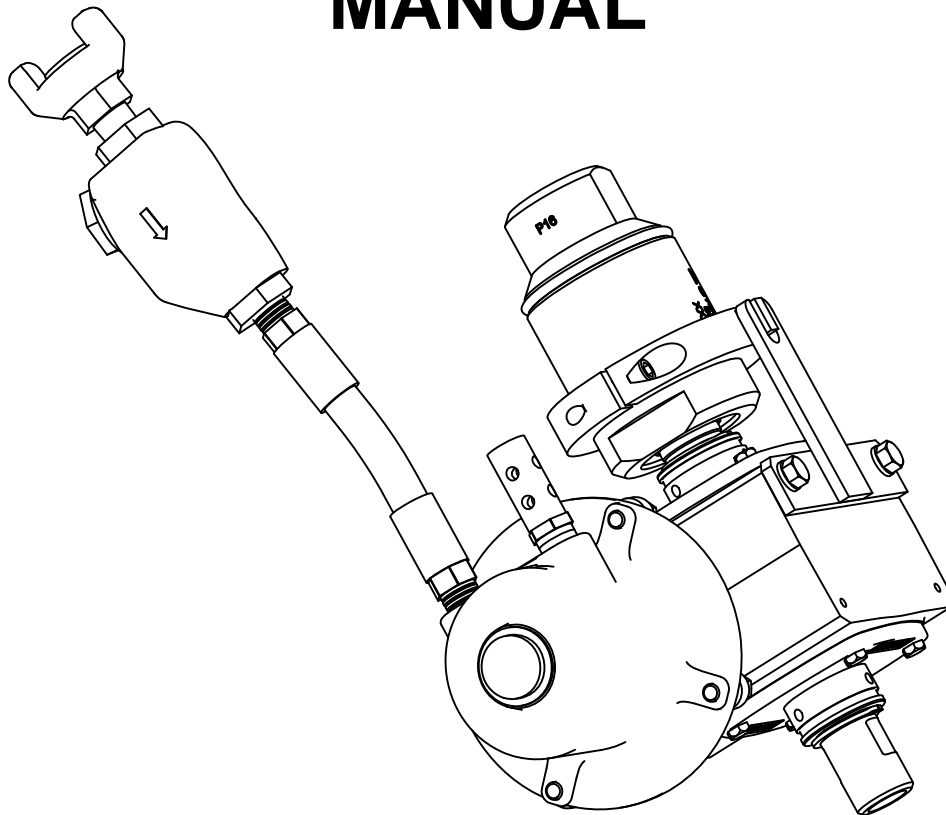

466 S. Skylane Dr. Durango, Colorado 81303
www.stoneagetools.com

(970) 259-2869 Phone (970) 259-2868 Fax
sales@stoneagetools.com

TABLE OF CONTENTS

| | |
|-----|-------------------|
| 1.0 | INTRODUCTION |
| 2.0 | SAFETY WARNING |
| 3.0 | DESCRIPTION |
| 4.0 | PARTS LIST |
| 5.0 | ASSEMBLY DRAWINGS |
| 6.0 | WARRANTY |
| | APPENDIX |
| | Air Motor |
| | SM Swivel Manual |

1.0 INTRODUCTION

This manual was prepared to provide the operator with the basic information needed to operate and service this equipment. The operating recommendations in the manual will insure that you receive satisfactory performance. All operating personnel responsible for the care of this equipment should be familiar with the information in this manual.

If you have any questions or problems with this equipment, please contact the distributor you obtained the product from, or the manufacturer:

StoneAge, Inc.
466 S. Skylane Dr.
Durango, CO 81303
(970) 259-2869
Fax (970) 259-2868
www.stoneagetools.com

2.0 SAFETY WARNING

Operations with this tool can be potentially dangerous if caution is not exercised prior to and during tool use. Please read and follow all of these instructions.

- 2.1** Only competent and trained persons should operate this equipment.
- 2.2** Do not exceed the maximum operating pressure specified for any component in a system.
- 2.3** This equipment should always be used with an operator controlled dump mechanism to release the high pressure water.
- 2.4** The immediate work area should be marked off to keep out untrained persons.
- 2.5** All personnel in the area should wear eye protection, and other protective clothing in accordance with specific conditions.
- 2.6** The tool should be securely supported. Strong thrust is created by waterjets and these forces can become unbalanced if a nozzle should become plugged.
- 2.7** Inspect the equipment for visible signs of deterioration, damage, or improper assembly. Do not operate until repaired. Make sure all threaded connections are tight and leak free.
- 2.8** Check to see that all control functions work properly before going to high pressure.
- 2.9** If it is necessary to have a person work near the cleaning jets, then it is this person who should have control of the pressure dump mechanism.

3.0 DESCRIPTION

The **SM-Air** is designed for high flow waterblast cleaning applications. It is capable of flow rates to 300 gpm at pressures up to 10,000 psi. It can be used with a variety of nozzle head designs for many different applications. Rotation of the nozzles provides uniform coverage over a large area.

The **SM** water swivel has a single high pressure seal that is long lasting and easy to service. The swivel has a 1" npt inlet, available as either 0 degrees or 90 degrees. The gearbox has a **60:1 ratio** and provides a speed range of 10 to 50 rpm. The rotation speed is variable and can be controlled with a valve in the inlet or exhaust air line. For very slow rotation speeds, it is best to use a speed control valve in the exhaust port of the air motor. A speed control needle valve is available as part number GP 058. The air motor requires 25 to 40 cfm at 80 psi.

4.0 PARTS LIST

| | | |
|-----------|-----------------|---|
| BR 155 | Muffler | 1 |
| CB 114 | Inlet Fitting | 1 |
| CST 130 | Hose | 1 |
| GP 057 | Lubricator | 1 |
| HF 131 | Retaining Ring | 1 |
| LM 016-4 | Air Motor | 1 |
| SM P16G-0 | Swivel | 1 |
| SM 162 | Torque Arm | 1 |
| SM 133-3 | Torque Clamp | 1 |
| SM 160-60 | Gearbox, Hollow | 1 |

SM-Air EXPLODED ASSEMBLY DRAWING

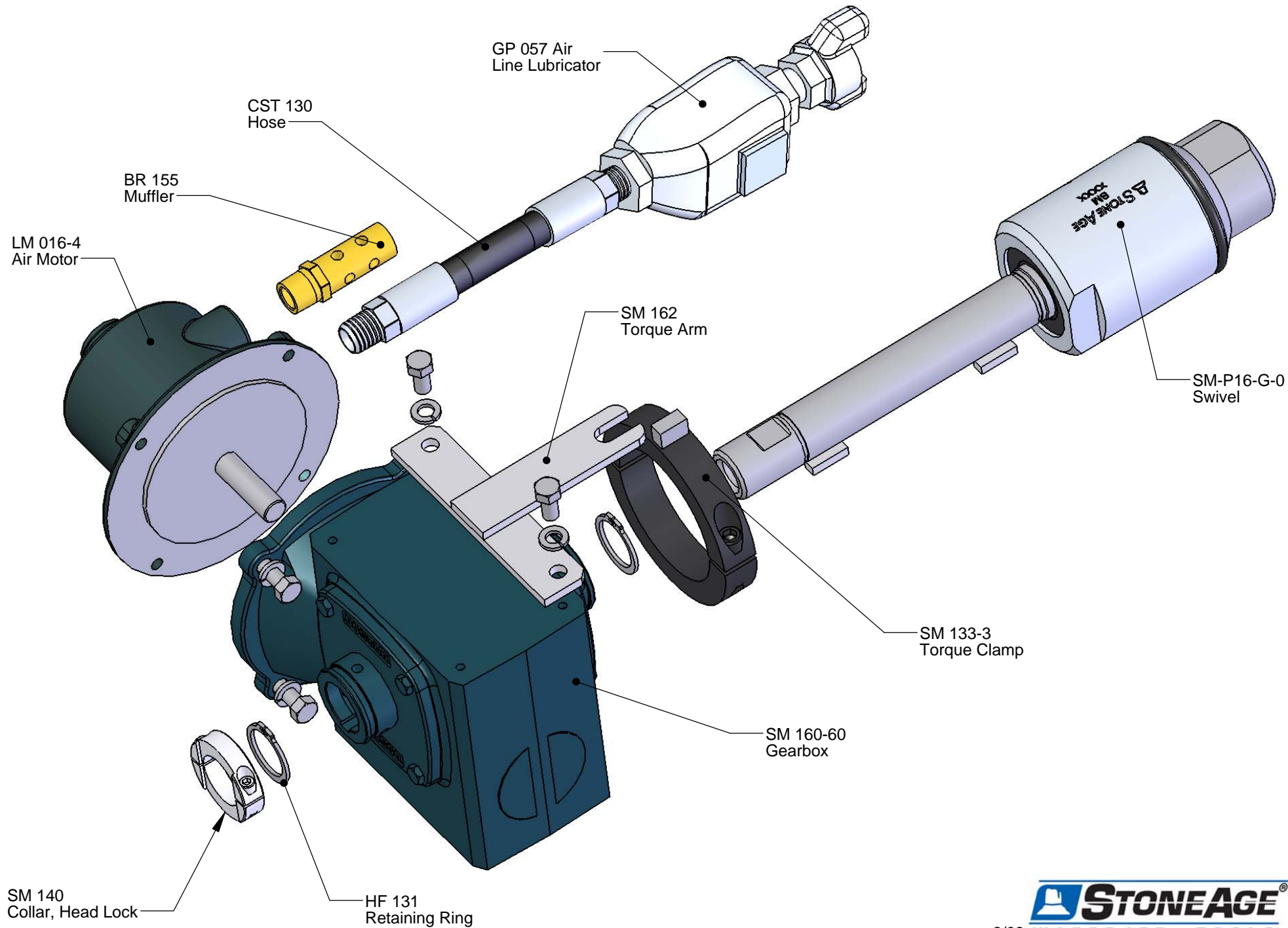

6.0 LIMITED WARRANTY

StoneAge, Inc. Warrants to the extent herein provided the products of its own manufacture against defects in material and workmanship under normal use and service for which the products were designed for a period of six (6) months after shipment from the factory. If such products should fail through defect in workmanship or material and specific written notice of failure is made within six (6) months after date of shipment from the factory, StoneAge, Inc. will either repair or replace any such items, F.O.B. its factory without charge. StoneAge, Inc. shall not be liable for expense incurred in repairs or alterations made outside the factory without the proper and prior authorization. StoneAge, Inc. shall have the option of requiring the return of the defective products to its factory, with transportation charges prepaid, to establish the claim. StoneAge, Inc. shall in no event be held liable for damages or delay resulting from or arising out of defective products nor for consequential damages or otherwise except for repair or replacement of items of defective material or workmanship as foresaid.

THIS WARRANTY IS EXPRESSLY IN LIEU OF ALL OTHER WARRANTIES EXPRESSED OR IMPLIED INCLUDING THE WARRANTIES OF MERCHANTABILITY AND FITNESS FOR USE AND NEITHER ASSUMES, NOR AUTHORIZES ANY PERSON TO ASSUME FOR STONEAGE, INC. ANY OTHER LIABILITY IN CONNECTION WITH THE SALE OF ITS PRODUCTS. THIS WARRANTY SHALL NOT APPLY TO PRODUCTS OR ANY PARTS THEREOF WHICH HAVE BEEN SUBJECT TO ACCIDENT, NEGLIGENCE, ALTERATION, ABUSE, OR MISUSE. STONEAGE, INC. MAKES NO WARRANTY WHATSOEVER IN RESPECT TO ACCESSORIES, PARTS OR PRODUCTS NOT MANUFACTURED BY STONEAGE, INC.

AM SERIES LUBRICATED AIR MOTORS

OPERATION & MAINTENANCE MANUAL



Model 2AM Shown



Model 4AM Shown

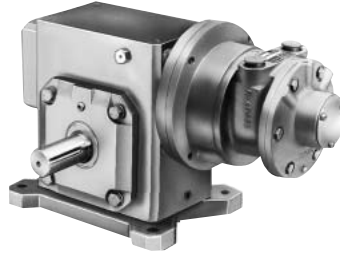

Model 6AM Shown



Model 16AM Shown

Thank you for purchasing this Gast product. It is manufactured to the highest standards using quality materials. Please follow all recommended maintenance, operational and safety instructions and you will receive years of trouble free service.

IMPORTANT: PLEASE READ THIS MANUAL AND SAVE FOR FUTURE REFERENCE.

General information

| • Clearances: | Model | Total End Clearance (in/mm) | Top Clearance (in/mm) |
|---------------|----------|-----------------------------|-----------------------|
| | 1AM/1 UP | 0.00020/0.0508 | 0.0015/0.0381 |
| | 2AM | 0.00025/0.0635 | 0.0015/0.0381 |
| | 2AM * | 0.00025/0.0635 | 0.0025/0.0635 |
| | 4AM | 0.00035/0.0889 | 0.0015/0.0381 |
| | 4AM * | 0.00035/0.0889 | 0.0025/0.0635 |
| | 6AM | 0.00035/0.0889 | 0.0015/0.0381 |
| | 8AM | 0.00048/0.1219 | 0.0015/0.0381 |
| | 16AM | 0.00060/0.1524 | 0.0015/0.0381 |

* Models with the last three digits greater than 500 (ie 2AM XXX-501)

- **Vane Life:** Depends upon speed, operating pressure and motor maintenance.
- **Operating Pressure:** 100 psi or below (7 bar)

Product Use Criteria:

- Operate at temperature up to 250°F (121°C).
- Protect unit from dirt and moisture.
- Use ONLY compressed air to drive motor.
- Air lines connected to motor should be the same size or the next size larger than the intake port for efficient output and speed control.
- Protect all surrounding items from exhaust air.
- Bearings are grease packed.
- Use Gast #AD220 or a detergent SAE#10 automotive engine oil for lubricating.



A Unit of **INX** Corporation

ISO 9001 & 14001 CERTIFIED

www.gastmfg.com

Lubrication

Use Gast #AD220 or a detergent SAE #10 automotive engine oil for lubricating. Lubricating is necessary to prevent rust on all moving parts. Excessive moisture in the air line may cause rust or ice to form in the muffler when air expands as it passes through the motor. Install a moisture separator in the air line and an after cooler between compressor and air receiver to help prevent moisture problems.

Manual Lubrication

Shut the air motor down and oil after every 8 hours of operation. Add 10-20 drops of oil to the air motor intake port.

Automatic Lubrication

Adjust inline oiler to feed 1 drop of oil per minute for high speed or continuous duty usage. Do Not overfeed oil or exhaust air may become contaminated.

Check intake and exhaust filters after first 500 hours of operation. Clean filters and determine how frequently filters should be checked during future operation. This one procedure will help assure the product's performance and service life.

Flushing

Flushing this product to remove excessive dirt, foreign particles, moisture or oil that occurs in the operating environment will help to maintain proper vane performance. Flush the motor if it is operating slowly or inefficiently.

Use only Gast #AH255B Flushing Solvent. DO NOT use kerosene or ANY other combustible solvents to flush this product.

1. Disconnect air line and muffler.
2. Add flushing solvent directly into motor. If using liquid solvent, pour several tablespoons directly into the intake port. If using Gast #AH255B, spray solvent for 5-10 seconds into intake port.
3. Rotate the shaft by hand in both directions for a few minutes.
4. **You must wear eye protection for this step.** Cover exhaust with a cloth and reconnect the air line. Slowly apply pressure until there is no trace of solvent in the exhaust air.
5. Listen for changes in the sound of the motor. If motor sounds smooth, you are finished. If motor does not sound like it is running smoothly, installing a service kit will be required. (See "Service Kit Installation").

Check that all external accessories such as relief valves or gauges are attached and are not damaged before operating product.

Shutdown

It is your responsibility to follow proper shutdown procedures to prevent product damage.

1. Turn off air intake supply.
2. Disconnect plumbing.
3. Remove air motor from connected machinery.
4. **Wear eye protection.** Keep away from air stream.
Use clean, dry air to remove condensation.
5. Lubricate motor with a small amount of oil in chamber. Rotate shaft by hand several times.

6. Plug or cap each port.
7. Coat output shaft with oil or grease.
8. Store motor in a dry environment.

SERVICE KIT INSTALLATION

Gast will NOT guarantee field-rebuilt product performance. For performance guarantee, the product must be returned to a Gast authorized service facility.

Service kit contents vary. Most contain vanes, end cap gasket, body gasket, bearings and a muffler element or felt.

Major and Minor Rebuilds

Tool kits which include a more in-depth rebuild manual are available through your Gast distributor.

These kits include the tools required to remove and reassemble end plates, bearings and shaft seals, and to set the proper end clearance. The rebuild manual also includes step by step instructions, including illustrations, to help achieve a successful rebuild. Gast Manufacturing, Inc. highly recommends using the air motor rebuild manual and tool kit when attempting a minor or major rebuild to your Gast air motor.

Minor Rebuild:

1. Remove the end cap.
2. Remove dead end plate bolts.
3. Remove dead end plate. (Use factory issued tool, do not use screwdriver to remove the end plate.)
4. Remove the dowel pins from the body and push back into end plate until flush or just below the machined surface of the end plate.
5. Remove vanes.
6. Clean parts. Check for scoring on the end plate and rotor assembly. If scoring exists, send unit to a Gast authorized service facility.
7. **Lubricated models only:** Lightly oil and reinstall vanes.
8. Place the proper end plate gasket on the end plate. If the original is damaged, replace with a new one supplied in the Service Kit.
9. Place the dead end plate on the body.
10. Press the bearing onto the shaft using a factory supplied bearing pusher.
11. Tap dowel pins into body and install end plate bolts. Tighten bolts to 75-100 in-lbs.
12. Set end clearance as required by model:
1AM-4AM and NL22-NL52 models - use the bearing taper from kit to lightly tap on inner race of the dead end bearing to free up and center the rotor in the body.
6AM-8AM models - lightly strike the drive end shaft with a soft hammer to push the rotor away from the drive end plate. The rotor must NOT rub on either end plate.
13. Reattach end cap.
14. **If the air motor is lubricated,** apply a few drops of Gast #AD220 lubricant into ports. Rotate shaft by hand for a few rotations.

Major Rebuild:

1. Remove the end cap.
2. Remove dead end plate bolts.

3. Remove dead end plate. (Use factory issued tool, do not use screwdriver to remove the end plate.)
4. Remove the dowel pins from the body and push back into end plate until flush or just below the machined surface of the dead end plate.
5. Remove rotor using an arbor press.
6. Remove vanes and ejection mechanism if reversible. (Ejection mechanisms may consist of vane springs, pins, caps or cam rings.)
7. Remove shaft seal and bearings from drive end plate and bearing from dead end plate. (Use factory issued tool.)
8. Do Not remove drive end plate bolts or drive end plate.
9. Clean parts. Check for scoring on the end plates and rotor assembly. If scoring exists, send unit to a Gast authorized service facility.
10. **For reversible models only:**
1AM and 1UP models - place a new cam ring between the rotor and the drive end plate.
2AM and 4AM models - place springs and caps in rotor.
6AM, 8AM and 16AM models - install push pins.
11. Place the drive shaft of the rotor assembly through the drive end plate. Press the drive bearing onto the drive shaft using a factory supplied bearing pusher.
12. Using the bearing taper from the Tool Kit, lightly tap on inner race of the drive end bearing to snug up rotor to drive end plate.
13. Install new vanes as required by model:
All single rotation units - the angle cuts on the vane face to center of the rotor.
Reversible units 2AM and 4AM - the notch on vane faces to center of the rotor.
6AM, 8AM and 16AM models - install the vane spring lip into the notch at one end of the vane and place in rotor vane slot with spring facing pushpin.
14. Place the proper end plate gasket on the body of dead end. If the original is damaged, replace with a new one supplied in the service kit.
If your air motor uses O-rings, place the new O-rings in the body groove. Some models do not use end plate gaskets or O-rings.
15. Place the dead end plate on the body.
16. Install the dead end bearing and press into place with bearing pusher tool from tool kit.
17. Install the dowel pins.
18. Fully tighten the remaining bolts to 75-100 in-lbs.
19. Set end clearance as required by model:
1AM-4AM and NL22-NL52 models - use the bearing taper from the Tool Kit and lightly tap on the inner race of the dead end bearing to free up and center the rotor in the body.
6AM-8AM models - lightly strike the drive end shaft with a soft hammer to push the rotor away from the drive end plate. The rotor must NOT rub on either end plate.
20. Apply a small amount of grease to bearing seal and install the drive end bearing seal by pressing flush with bearing pushing tool from Tool Kit.
21. Reattach end cap.
22. **If the air motor is lubricated**, apply a few drops of Gast #AD220 lubricant into ports and rotate shaft by hand for a few rotations.

EXPLODED PRODUCT VIEWS, PARTS & ORDERING INFORMATION

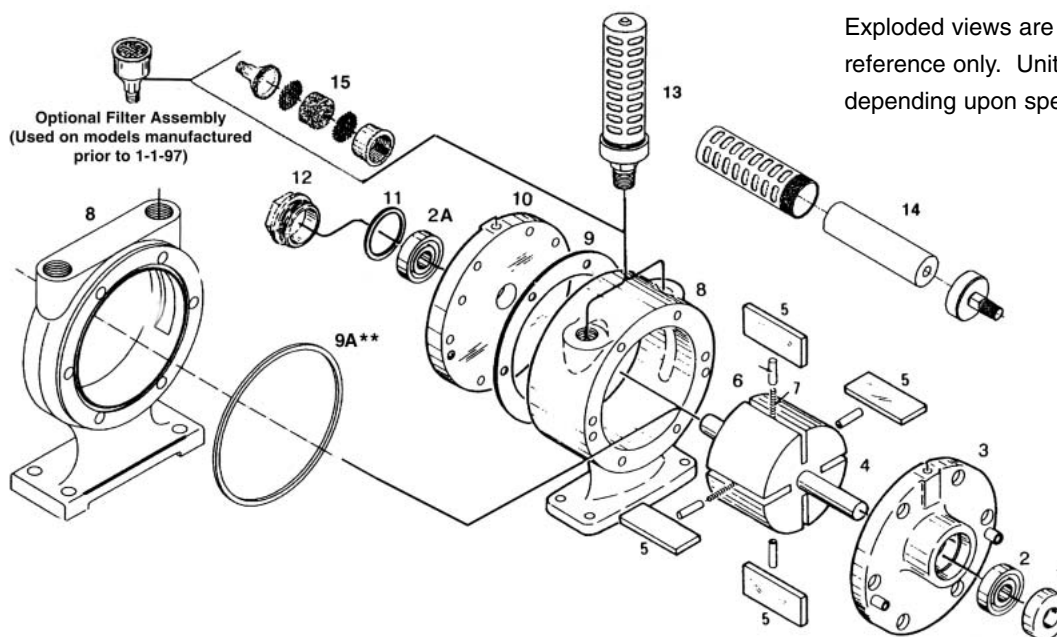

Exploded views are shown for reference only. Units may vary depending upon specific model.

4AM SERIES

| REF# | DESCRIPTION | QTY | 4AM-FRV-13C | 4AM-NRV-22B | 4AM-FRV-24 | 4AM-NRV-50C | 4AM-NRV-54A | 4AM-NRV-70C | 4AM-ARV-119 METRIC | 4AM-ARV-120 METRIC |
|--------|-------------------|-----|-------------|-------------|------------|-------------|-------------|-------------|-----------------------|-----------------------|
| 1 Δ | SHAFT SEAL | 1 | AC466B | AC466B | NAS2 | B2328 | AA466B | B2328 | B2328 | B2328 |
| 2 Δ | DRIVE END BEARING | 1 | AA299J | AA299J | AA299J | AB519 | AA299J | AB519 | AB519 | AB519 |
| 2A Δ | DEAD END BEARING | 1 | AA299J | AA299J | AA299J | AA299J | AA299J | AA299J | AA299J | AA299J |
| 3 | DRIVE END PLATE | 1 | AC727 | AC665 | AC727 | AG707 | AC665 | AG707 | AK425A | AK425A |
| 4 | ROTOR ASSEMBLY | 1 | AB617 | AB617 | AM426 | AM455A | AM411 | AM319A | AM455C | AM455B |
| 5 Δ | VANE | 4 | AB876 | AB876 | AB876 | AB876 | AB876 | AB876 | AB876 | AB876 |
| 6 Δ | PUSH PINS | 4 | AM467 | AM467 | AM467 | AM467 | AM467 | AM467 | AM467 | AM467 |
| 7 Δ | VANE SPRING | 2 | AM466 | AM466 | AM466 | AM466 | AM466 | AM466 | AM466 | AM466 |
| 8 | BODY | 1 | AM425 | AM410 | AM425 | AM410 | AM410 | AM410 | AM410M | AM410M |
| 9 Δ ** | SHIMS | 2 | B330 | B330 | B330 | B330 | B330 | B330 | B330 | B330 |
| 10 | DEAD END PLATE | 1 | AC728 | AC728 | AC727 | AC728 | AC728 | AC728 | AB622M | AB622M |
| 11 Δ | END CAP GASKET | 1 | AA46 | AA46 | | AA46 | AA46 | AA46 | AA46 | AA46 |
| 12 | DEAD END CAP | 1 | AM307D | AM307D | | AM307D | AM307D | AM307D | AM307D | AM307D |
| 13 | MUFFLER ASSEMBLY | 1 | AL445 | AL445 | AL445 | AL445 | AL445 | AL445 | AL445 | AL445 |
| 14 Δ | MUFFLER CARTRIDGE | 1 | AL458 | AL458 | AL458 | AL458 | AL458 | AL458 | AL458 | AL458 |
| 15 Δ | MUFFLER FELT | 1 | AC983 | AC983 | AC983 | AC983 | AC983 | AC983 | AC983 | AC983 |
| *** | SERVICE KIT | 1 | K205 | K205 | K205G | K206A | K279 | K280A | K206C | K206B |

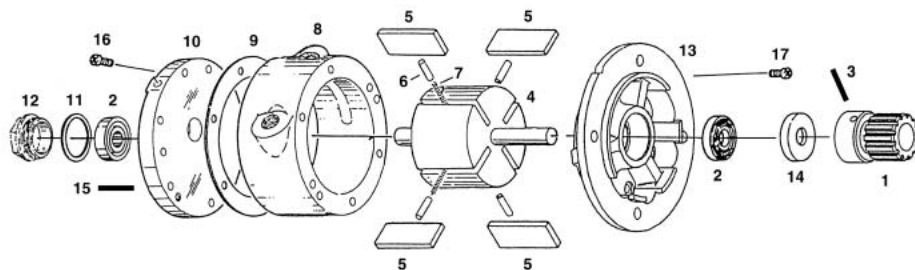

4AM SERIES

| REF# | DESCRIPTION | QTY | 4AM-RV-75 |
|------|--------------------|-----|-----------|
| 1 | GEAR STD. | 1 | AA294 |
| 2 Δ | BEARING | 2 | AA299J |
| 3 | PIN | 1 | AA297 |
| 4 | ROTOR | 1 | AA293 |
| 5 Δ | VANE | 4 | AB876 |
| 6 Δ | SPRING PIN | 4 | AM467 |
| 7 Δ | SPRINGS | 2 | AM466 |
| 8 | BODY | 1 | AM410 |
| 9 Δ | SHIMS | 2 | B330 |
| 10 | DEAD END PLATE | 1 | AC728 |
| 11 Δ | END CAP GASKET | 1 | AA46 |
| 12 | END CAP | 1 | AM307D |
| 13 | DRIVE END PLATE | 1 | AA424 |
| 14 | SEAL | 1 | AA466B |
| 15 | DOWEL PINS | 4 | AB162 |
| 16 | 1/4-28 x .50 PFHMS | 6 | BB631 |
| 17 | 1/4-28 x .625 SHCS | 6 | BB634 |
| *** | SERVICE KIT | 1 | K205 |

*** Item not shown.

** #AL484 (9A) O-ring replaces shims on some models.

Δ Denotes parts included in the Service Kit.

Parts listed are for stock models. For specific OEM models, please consult the factory. When corresponding or ordering parts, please give complete model and serial numbers.

PART NO. 45-200 D170PL (Rev. D)

TROUBLESHOOTING CHART

| Problem | | | | | |
|------------|-----------|-----------|----------|---------------------------|--|
| Low Torque | Low Speed | Won't Run | Runs Hot | Runs Well Then Slows Down | Reason & Remedy For Problem. |
| ● | ● | ● | | | Dirt or foreign material present. Inspect and clean. |
| ● | ● | ● | | | Internal rust. Inspect and clean. |
| ● | ● | ● | ● | ● | Vanes misaligned. Realign vanes. |
| ● | ● | | | | Low air pressure. Increase pressure. |
| | ● | | | | Air line too small. Install larger line(s). |
| | ● | | | ● | Restricted exhaust. Inspect and repair. |
| ● | ● | ● | | ● | Motor is jammed. Disassemble and repair. |
| | ● | | | ● | Air source inadequate. Inspect and repair. |
| | ● | | | ● | Air source too far from motor. Reconfigure setup. |

AUTHORIZED SERVICE FACILITIES

Gast Manufacturing Inc.
2550 Meadowbrook Road
Benton Harbor, MI 49022
TEL: 616-926-6171
FAX: 616-927-0808
www.gastmfg.com

Gast Manufacturing Inc.
505 Washington Ave
Carlstadt, NJ 07072
TEL: 201-933-8484
FAX: 201-933-5545

Brenner Fiedler & Assoc.
13824 Bentley Place
Cerritos, CA 90701
TEL: 800-843-5558
TEL: 310-404-2721
FAX: 310-404-7975

Gast Manufacturing Co., Ltd
Beech House, Knaves Beech
Business Centre, Loudwater
High Wycombe, Bucks HP 10 9SD
England
TEL: 44 628 532600
FAX: 44 628 532470

Wainbee Limited
215 Brunswick Blvd.
Pointe Claire, Quebec
Canada H9R 4R7
TEL: 514-697-8810
FAX: 514-697-3070

Wainbee Limited
5789 Coopers Avenue
Mississauga, Ontario
Canada L4Z 3S6
TEL: 905-568-1700
FAX: 905-568-0083

Japan Machinery Co., Ltd.
Central PO Box 1451
Tokyo, 100-91 Japan
TEL: 81-3-3573-5421
FAX: 81-3-3571-7865
or: 81-3-3571-7896

General Correspondence
should be sent to:
Gast Mfg. Inc./A Unit of IDEX Corporation
P O Box 97
Benton Harbor, MI 49023-0097



A Unit of IDEX Corporation

ISO 9001 & 14001 CERTIFIED

www.gastmfg.com